

**CFL-SP002B**

**SPECIALTY SERIES: SAILBOAT SERIES**



**General Product Description**

Liner Dimensions: 16' x 7' x 7.5' or to order

Depth of Relief: 3.0"

Dimensions and surface texture may vary according to project specifications

**Fabrication and Installation**

All liners are fabricated from urethane rubber (+/- 50 uses)

Form liners can be reinforced with wood or other suitable material as specified

**Release Agents**

Release agents must be approved and applied according to CFL's installation instructions

NO SUBSTITUTIONS WILL BE ALLOWED WITHOUT PRIOR WRITTEN APPROVAL FROM PRODUCT ENGINEER OR ARCHITECT  
Please call CFL for full specifications and installation instructions for our form liner products

**CFL-SP002B**

**SPECIALTY SERIES: SAILBOAT SERIES**

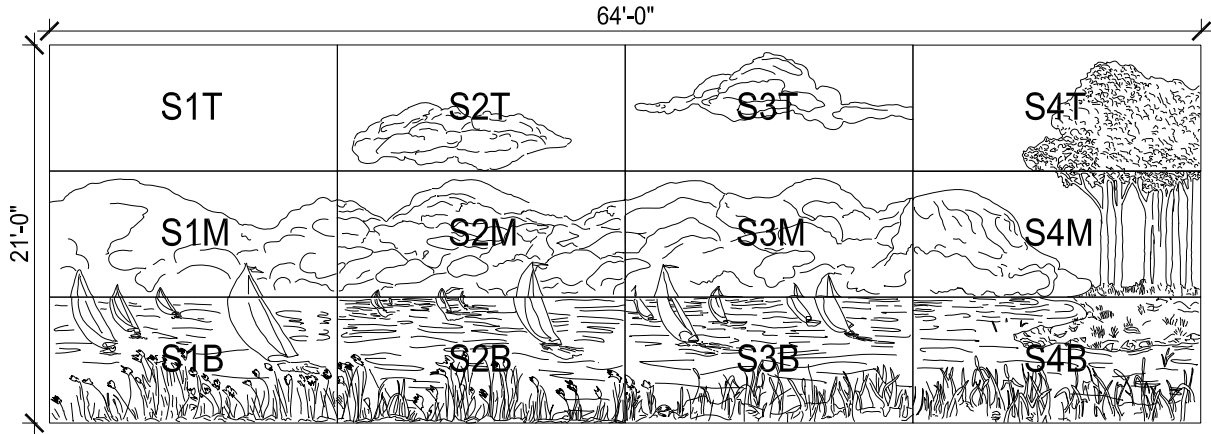

NO SUBSTITUTIONS WILL BE ALLOWED WITHOUT PRIOR WRITTEN APPROVAL FROM PRODUCT ENGINEER OR ARCHITECT  
Please call CFL for full specifications and installation instructions for our form liner products

## CFL-SP002B SPECIALTY SERIES: SAILBOAT SERIES

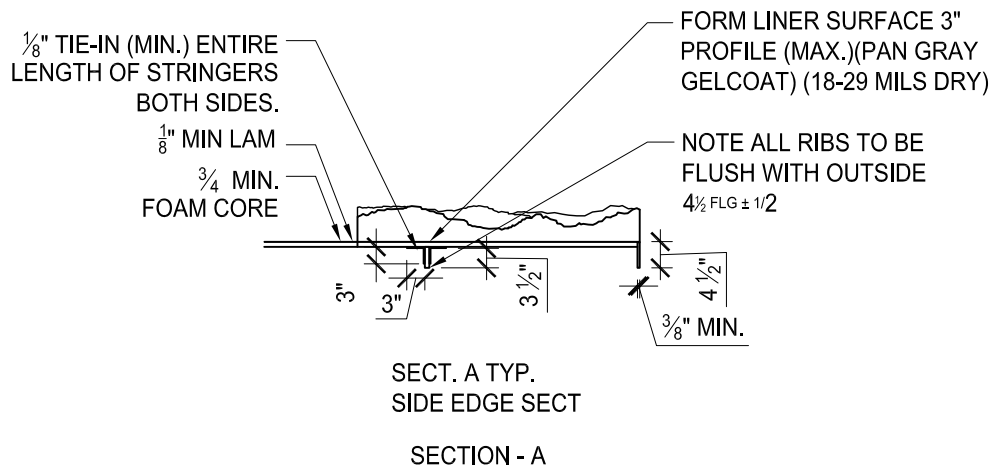
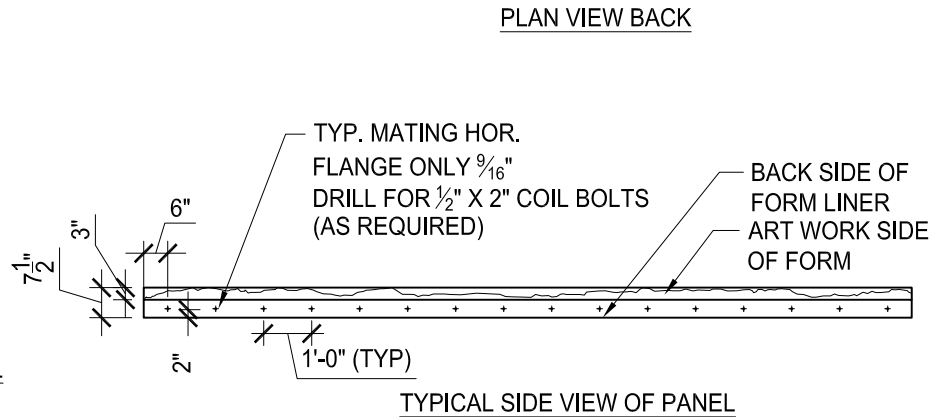
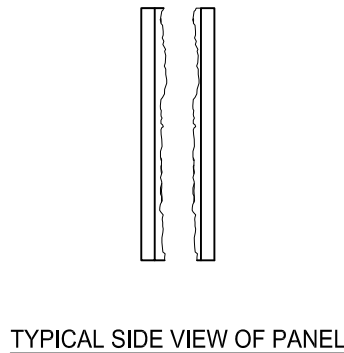
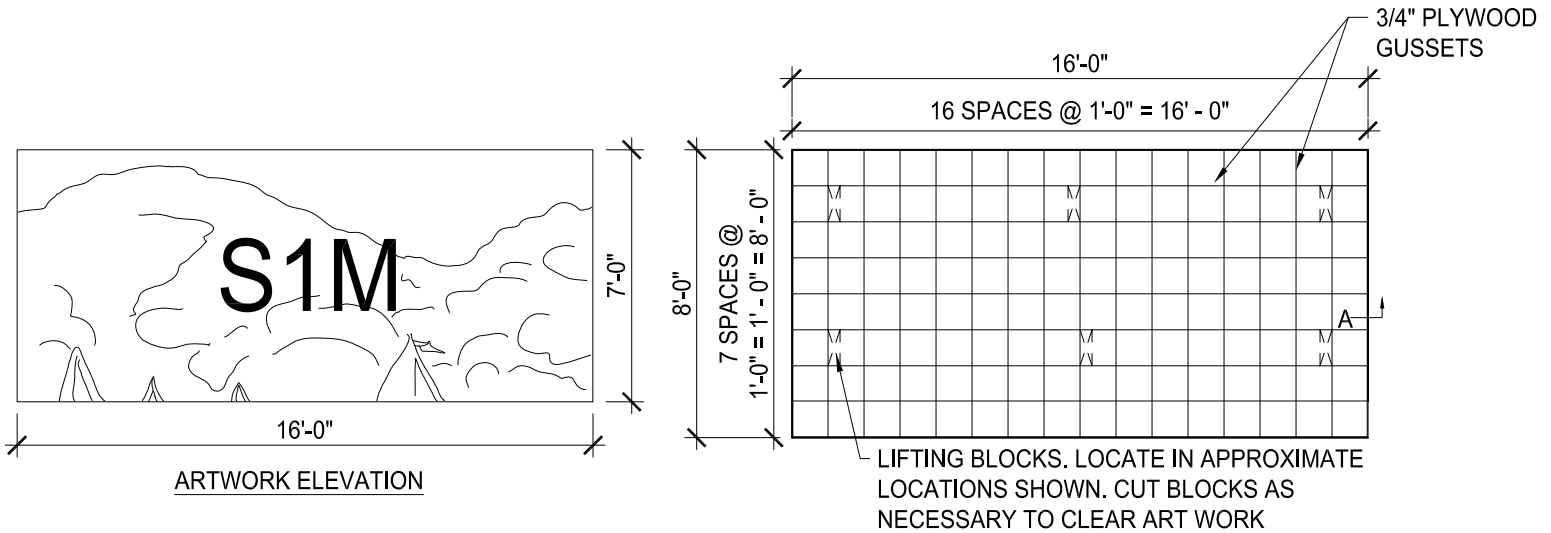

NO SUBSTITUTIONS WILL BE ALLOWED WITHOUT PRIOR WRITTEN APPROVAL FROM PRODUCT ENGINEER OR ARCHITECT  
Please call CFL for full specifications and installation instructions for our form liner products