

CFL-SP003B

SPECIALTY SERIES: SCATTERED LEAF SERIES B

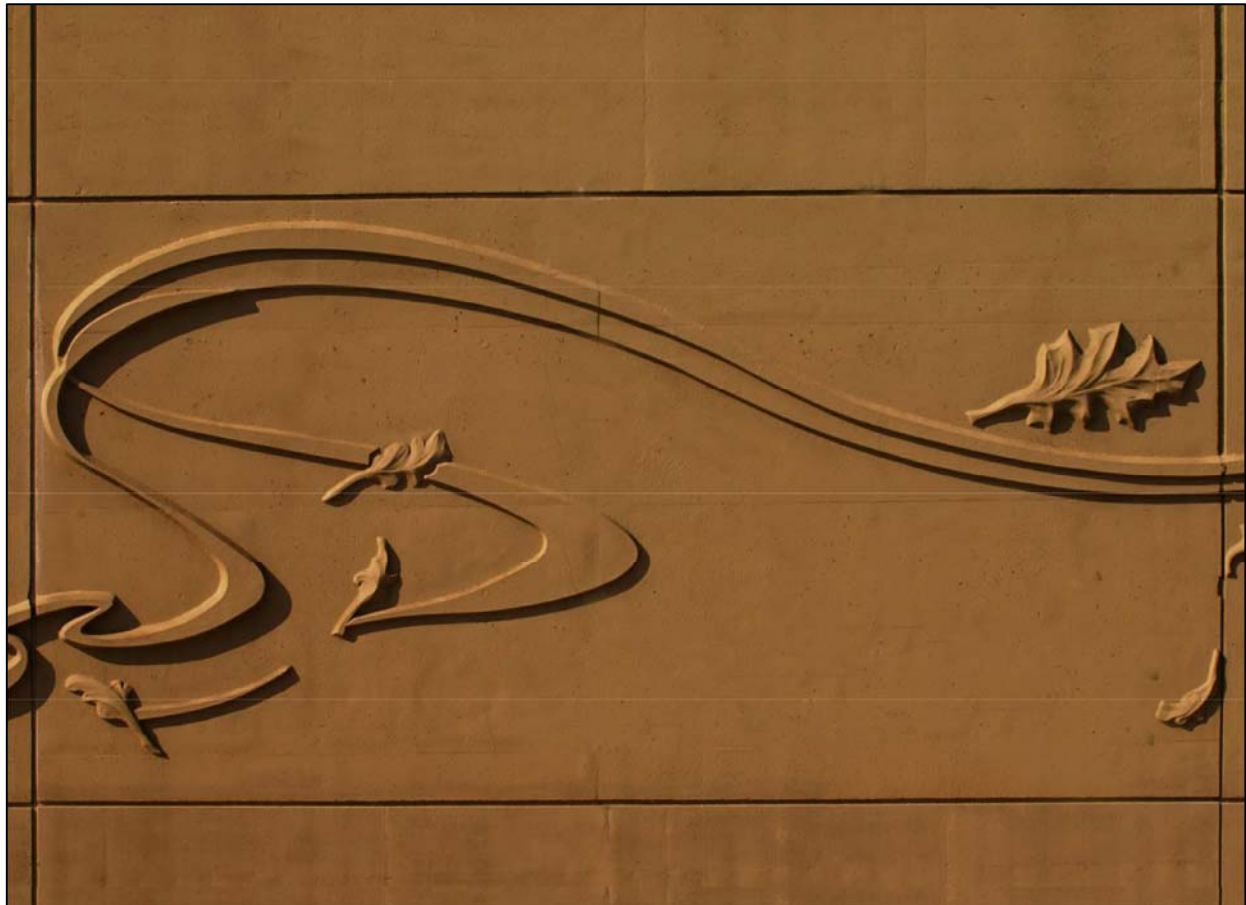

General Product Description

Liner Dimensions: 8' x 4' x 7.5' or to order

Depth of Relief: 3.0"

Dimensions and surface texture may vary according to project specifications

Fabrication and Installation

All liners are fabricated from urethane rubber (+/- 50 uses)

Form liners can be reinforced with wood or other suitable material as specified

Release Agents

Release agents must be approved and applied according to CFL's installation instructions

NO SUBSTITUTIONS WILL BE ALLOWED WITHOUT PRIOR WRITTEN APPROVAL FROM PRODUCT ENGINEER OR ARCHITECT
Please call CFL for full specifications and installation instructions for our form liner products

CFL-SP003B

SPECIALTY SERIES: SCATTERED LEAF SERIES B

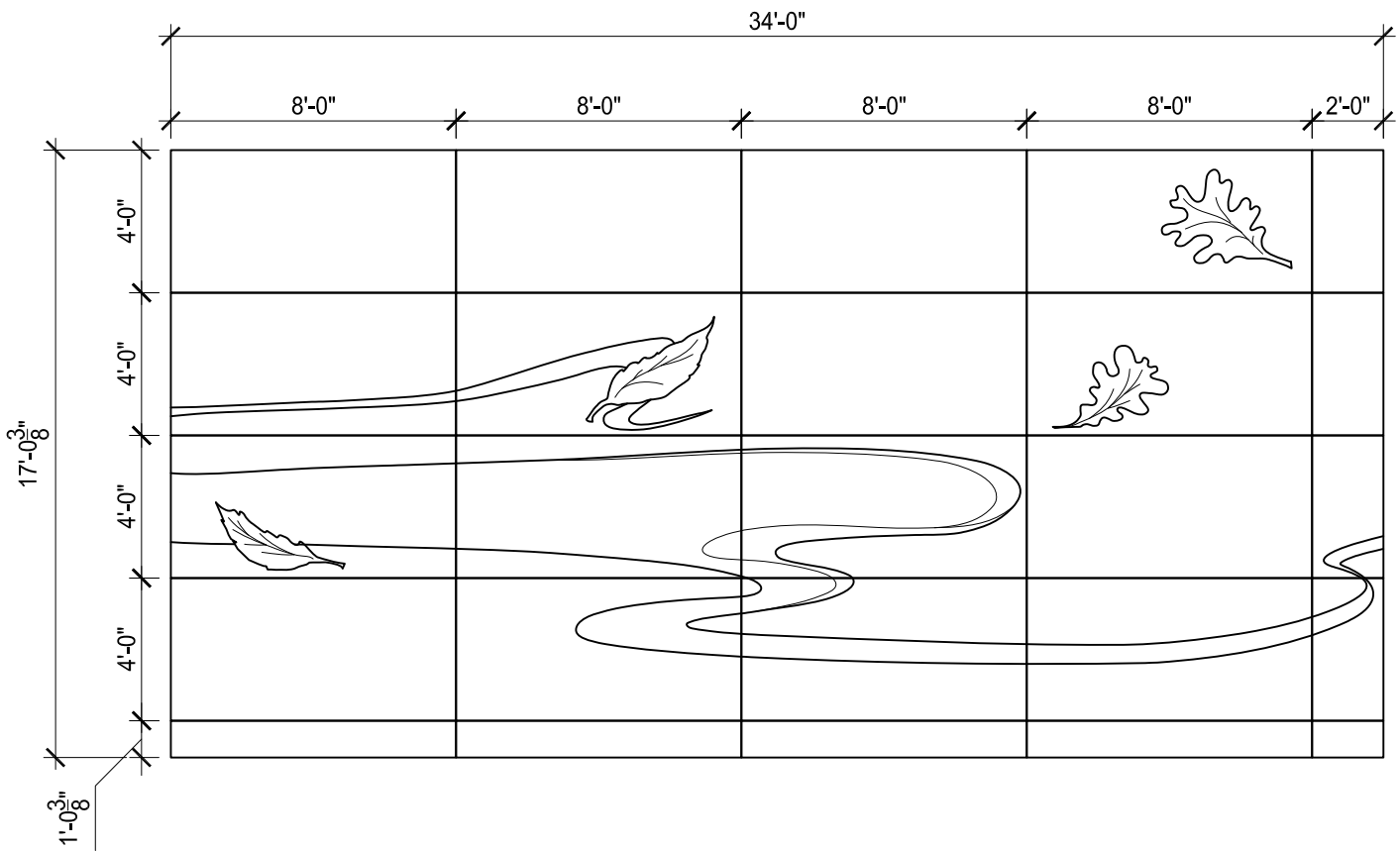

NO SUBSTITUTIONS WILL BE ALLOWED WITHOUT PRIOR WRITTEN APPROVAL FROM PRODUCT ENGINEER OR ARCHITECT
Please call CFL for full specifications and installation instructions for our form liner products

CFL-SP003B

SPECIALTY SERIES: SCATTERED LEAF SERIES B

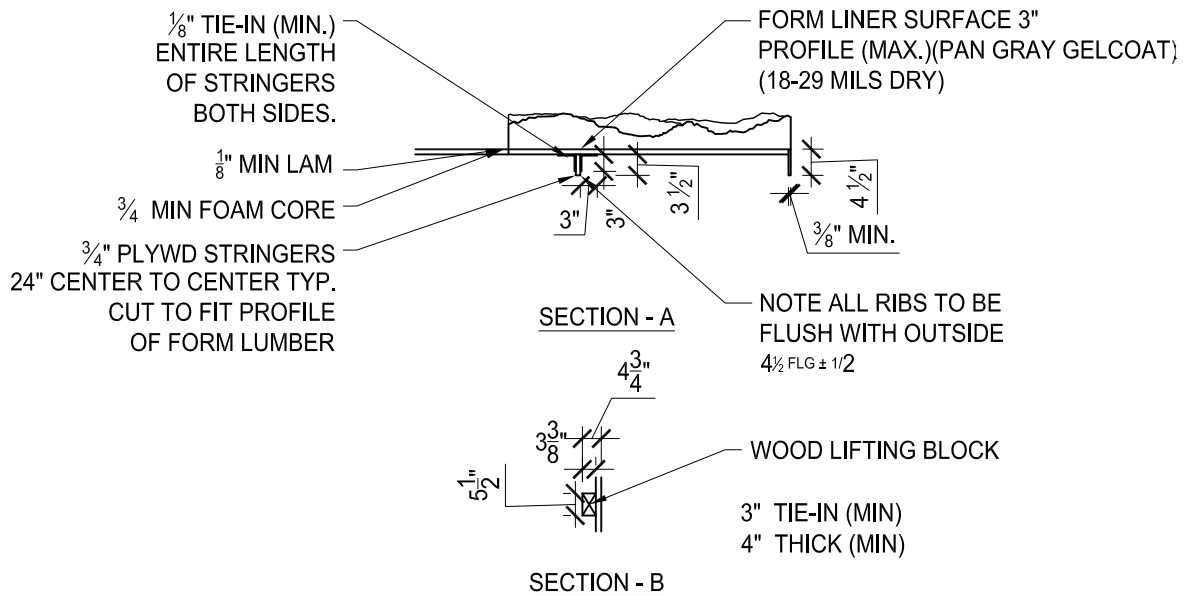
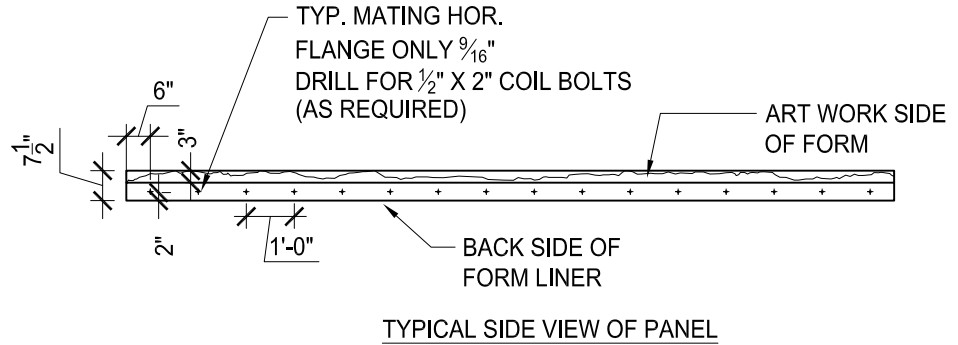
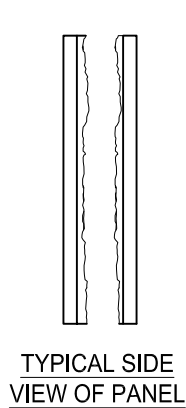
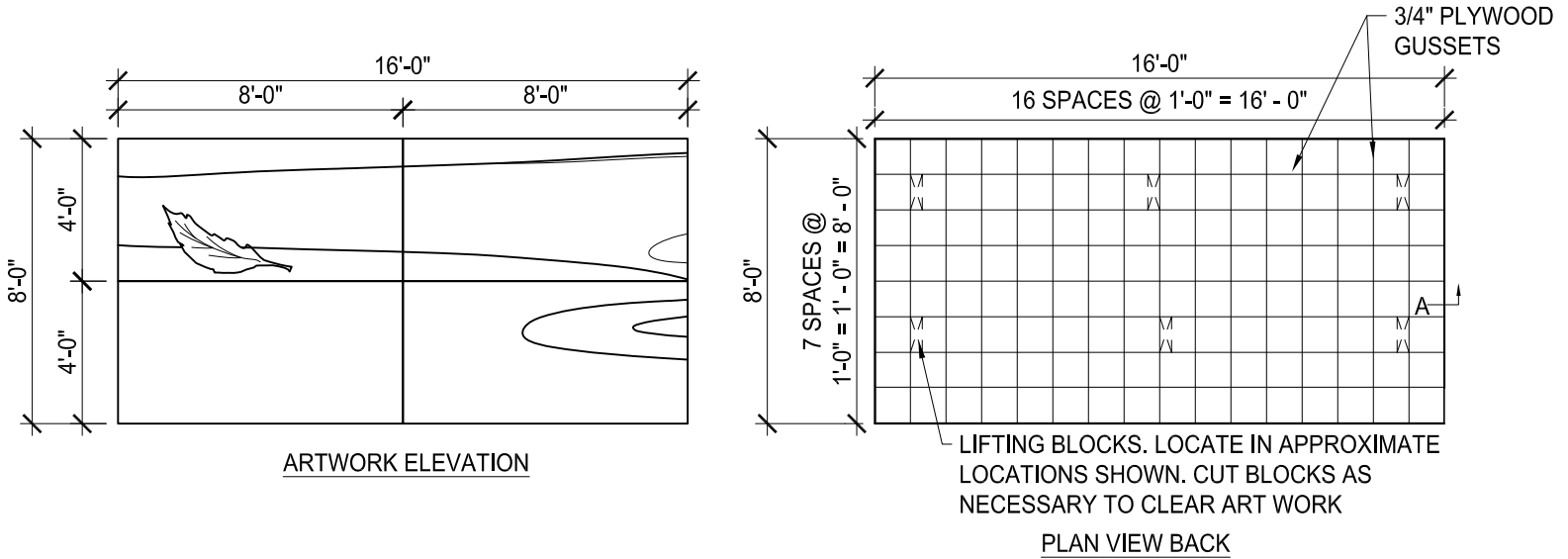

NO SUBSTITUTIONS WILL BE ALLOWED WITHOUT PRIOR WRITTEN APPROVAL FROM PRODUCT ENGINEER OR ARCHITECT
 Please call CFL for full specifications and installation instructions for our form liner products